

FABRIJET

HS FT B II

HIGH SPEED FABRIJET TRANSFER



Dye sublimation digital printer on paper for textile transfer

See product information from DGI App & DGI facebook



Technical Specification

Print Speed	Production Mode 180 m ² /h	Quality Mode 105 m ² /hr
Print Resolution	600 x 600dpi (1 Pass)	600 x 1,200dpi (2 Pass)
Max Print Width	1,800 mm	
Max Resolution	up to 1200dpi	
Gradation	variable dots / 4 to 72 pL / up to 16 grayscale	
Print Mode	Bi-Direction / Uni-Direction , Normal / Interleave I ,II / DBF I ,II,III	
Printhead	Kyocera 2,656 nozzle Printhead with piezo electric technology inkjet (4 heads in single row)	
Color	4 Color - Cyan, Magenta, Yellow, Black	
Ink	DGI original water based F120 / F131 dye sublimation ink	
Interface	TCP / IP	
Environmental Range	Temperature : 20~28 °C	Humidity : 40~70%
	Environment condition may affect on final printing quality.	
Electricity Requirements	Printer : 220~240V VAC Single Phase, 50/60 Hz / 20A	Winder & Refill : 220~240V VAC Single Phase, 50/60 Hz / 5A

※ All specifications are subject to change without notice.

Dimension for Installation

	Uncrated				Crated			
	Length (mm)	Width (mm)	Height (mm)	Weight (kg)	Length (mm)	Width (mm)	Height (mm)	Weight (kg)
Printer	4,000	900	1,640	1,200	4,400	1,330	2,100	1,600
Winder & Refill	2,810	630	810	200	3,440	900	1,100	350

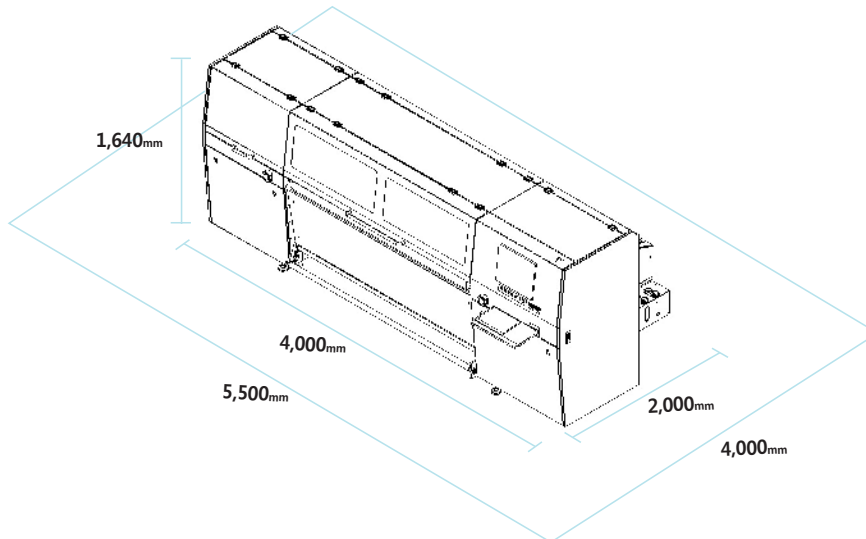

DGI Original Ink

MODEL	F120 (Standard Original)	F131 (Premium Original)
Type	Water based Dye sublimation	Water based Dye sublimation
Capacity	5Kg / Bottle	1Kg / Bottle
Color	C, M, Y, K and Cleaning Solution	C, M, Y, K and Cleaning Solution
Package	3 Bottles / Box	16 Bottles / Box



52, Cheongdam-Ro, Yangju-si, Gyeonggi-do, Korea, 482-020
 TEL : +82-31-820-8900 A/S : +82-31-820-8880
 FAX : +82-31-820-8990 E-MAIL : sales@dgi-net.com
 www.dgi-net.com
 www.facebook.com/dgikorea



ISO 9001:14001 Certified